

STONE

Design Hangar Group

STONE SP



Stone is characterized by almost sculptured volumes, where the lightness of blown glass is opposed to the solidity of linear geometries. In this counterpoint, between the use of a material naturally tending to round shapes, and a rigorous design requiring edges and orthogonal lines, the balance of a bright, original composition is expressed.

LED light source.

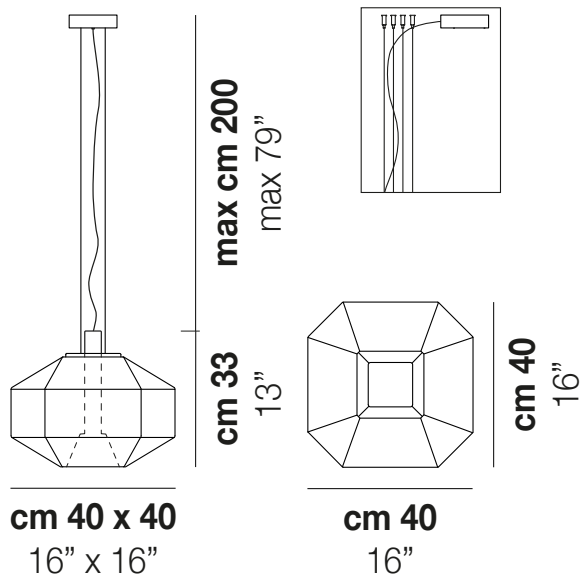

STONE SP

TECHNICAL DATA:



CERTIFICATIONS:



LIGHT SOURCES

LED SOURCE	Power / Voltage	Beam Angle
LED 2700K DIM2	1x2 W + 29 V	27°
LED 2700K DIM3	1x2 W + 29 V	36°
LED 3000K DIM2	1x2 W + 29 V	27°
LED 3000K DIM3	1x2 W + 29 V	36°

VOLUME	Mc 0,16
GROSS WEIGHT	Kg 13
NET WEIGHT	Kg 9

download



SHADE FINISHING



CRBC FUBC

FRAME FINISHING



NN